

PEOPLE ENTRANCE MANAGEMENT SYSTEM

VP-PM5020DC-SGT3 DOUBLE CORE SLIDING BARRIER GATE



FEATURES

- Speed gate series sliding barrier
- Single machine core with Bi-directional operation supported
- LED Direction indicators at each side
- Full height operation with passage width of $\leq 600\text{mm}$
- Throughput rate of 35 persons/minute
- High Security with built-in anti-tailing & anti-collision sensors
- Integration support with any RFID/Biometric Reader through NO input
- Top quality AISI 304 grade SS construction with IP44 rating

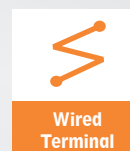
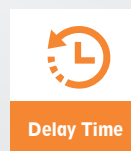
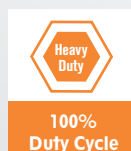

TECHNICAL SPECIFICATIONS

VP-PM5020DC-SGT3

Parameter	Specifications
Passage Width	600mm
Throughput Rate	35 p/m
Flap Type	Tempered glass flaps with integrated mold machine core
Power Supply	100~240 V AC
Operational Voltage	24 VDC
Max Power Consumption	35W
Frequency	50~60 Hz
Protection Level	IP44
Working Temperature	-25°C~+70°C
Electro-Magnetic Drive	DC
Dimension	1500x300x980mm
Net Weight	62 kg
Certifications	CE, FCC, ROHS

*Exact products and specifications shown may vary by geographic region and are subject to change without notice. Product image & weights, measurements are approximate and may vary.

DIMENSIONS

Unit: mm

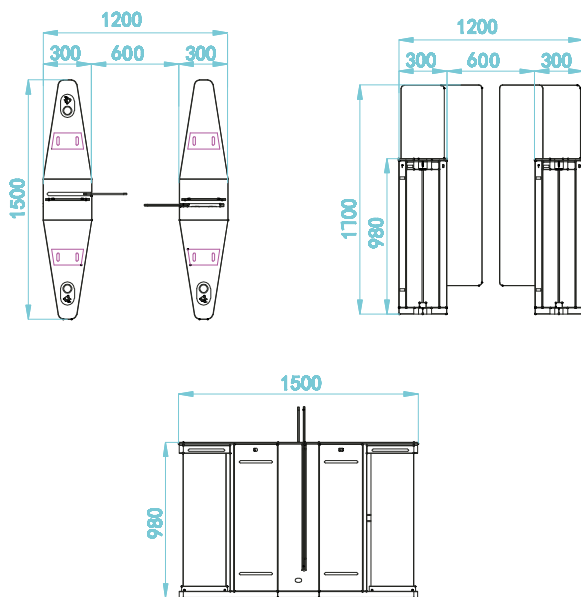

VANTAGE INTEGRATED SECURITY SOLUTIONS LIMITED.

B3, Bredon House 321, Tenttenhall Road Tettenhall, Wolverhampton

West Midlands, WV6 0JZ United Kingdom

Ph: +44-1902-793383, Email: sales@vantagesecurity.com

www.vantagesecurity.com

(AN ISO 9001 : 2008, ISO 14001:2004 CERTIFIED COMPANY)

