

ULTRA HIGH DEFINITION 16MP IP FISHEYE DOME CAMERA

VP-NC75116PD-8AX1 360° OUTDOOR CAMERA



FEATURES

8 x 1/1.9" Progressive Scan Sensor

Horizontal angle of view: 360°, Vertical angle of view: 180°

Inbuilt WDR, 3D DNR, BLC, HLC, Defog functions

23X optical zoom, 16X digital zoom

Multiple ePTZ streams with preset and patrol function

On board storage supported by Micro SD / SDHC / SDXC card up to 128 GB



TECHNICAL SPECIFICATIONS

VP-NC75116PD-8AX1

Camera	Image sensor	1/1.9" Progressive Scan Sensor
	Signal System	PAL/NTSC
	Effective Pixels	4000(H) × 3072(V)
	Minimum Illumination	Color: 0.002 Lux @ (F1.8, AGC ON), B/W: 0.0002Lux @ (F1.8, AGC ON)
	Gain Control	Auto
	White Balance	Auto (2000K to 10000K)
	Signal to Noise	> 62 dB
	Auto Iris	DC Drive
Lens	Lens Type	f4.0mm/ F1.8
	Angle of View	Horizontal angle of view: 360°, Vertical angle of view: 180°
	Focus	Fixed
Compression	Video compression	H.264 / MJPEG
	Audio compression	G.711/G.722.1/G.726/MP2L2/AAC/PCM
	H.264 codec profile	Main profile
	Video Bit Rate	32 Kbps ~ 16Mbps
	Audio Bit Rate	64Kbps(G.711) / 16Kbps(G.722.1) / 16Kbps(G.726) / 32-192Kbps (MP2L2) / 16-64Kbps(AAC)
Resolution and Frame Rate	Max. Resolution	2 × 2400 × 3840
	Frame rate	50Hz: 2 X 2400 X 3840@ 25fps 60Hz: 2 X 2400 X 3840@ 30fps
Operational Features	Wide Dynamic Range	Supported
	Backlight compensation	Yes, zone configurable
	DNR	Inbuilt 3D DNR (Digital Noise Reduction) circuit
	High Light Compensation	Supported
	Codec streaming capability	Dual
	Image settings	Rotate mode, Saturation, brightness, contrast, sharpness adjustable through client software or web browser
	Security	User authentication, watermark
	Alarm trigger	Motion detection, error Tampering alarm, Network disconnect, IP address conflict, Storage full
Network & Remote Monitoring	Protocols	TCP/IP,ICMP,HTTP,HTTPS,FTP,DHCP,DNS,DDNS,RTP,RTSP,RTCP, PPPoE,NTP,UPnP,SMTP, SNMP,IGMP,802.1X,QoS,IPv6,Bonjour
	System compatibility	ONVIF, PSIA, CGI,ISAPI
	CMS	Full function CMS (Central monitoring software)
	Mobile Client Application	Supports android and iOS APP for Smart phone and tablets
	Bandwidth control	VBR (Automatic) and CBR (Manual) supported
	Onboard Storage	Local storage: Built-in Micro SD/SDHC/SDXC card slot, up to 128 GB,
	Network Storage	NAS
Interface	Ethernet	1 x RJ45 10/100/1000 Ethernet port
	Fiber	1 x 10/100/1000 Fiber Interface
	Audio Input	1
	Audio Output	1
	Alarm Input	7
	Alarm Output	2
	CVBS Output	1 x BNC Channel

TECHNICAL SPECIFICATIONS

VP-NC75116PD-8AX1

Electrical	Power Requirement	30 VDC \pm 10%
	Power Consumption	Max. 110W
Environmental	Enclosure	IP66 Weather Proof Outdoor Enclosure
	Operating Temperature	-40°C to + 65°C
	Operating Humidity	95% or less (non-condensing)
Mechanical	Color	Gray and Black
	Dimensions	274.9 x 250.3 mm
	Weight	4.5 Kg
Certifications	Certifications	UL, CE, FCC, RoHS

*Exact products and specifications shown may vary by geographic region and are subject to change without notice. Weights and measurements are approximate and may vary.

DIMENSIONS

Unit: mm

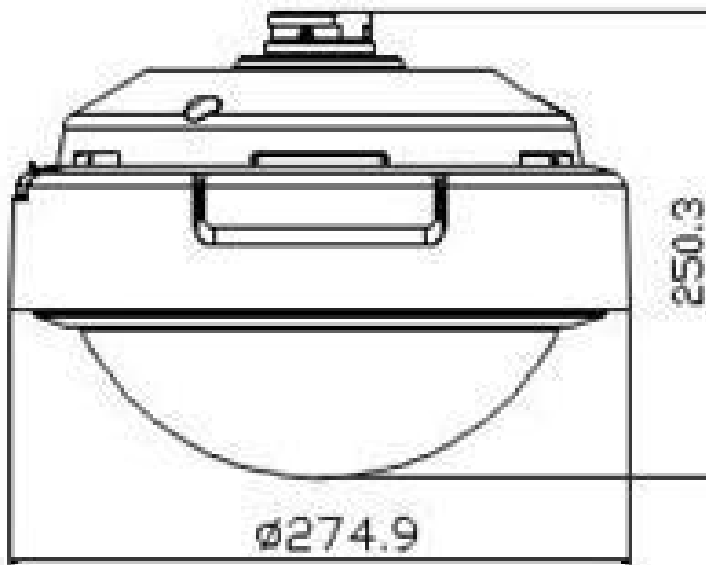

VANTAGE INTEGRATED SECURITY SOLUTIONS LIMITED

B3, Bredon House 321, Tenttenhall Road Tettenhall, Wolverhampton

West Midlands, WV6 0JZ United Kingdom

Ph: +44-1902793383, Email: sales@vantagesecurity.com

www.vantagesecurity.com

(AN ISO 9001 : 2008, ISO14001 : 2004 CERTIFIED COMPANY)

