

# PEOPLE ENTRANCE MANAGEMENT SYSTEM

## V-PM4011BL-SGT3 P TYPE SWING GATE BARRIER



### FEATURES

- Heavy-duty electro mechanical swing gate
- Selectable operating modes supported - single direction, bi-direction, always free or always locked
- LED status indicator & adjustable time out delay
- Half height operation with passage width of <math><600-900\text{mm}</math>
- Automatic reset of barrier gate after each passage
- Integration support with any smart card, RFID/ Biometric Reader through NO input
- Fail safe & fail lock function supported in case of emergency
- Top quality AISI 304 grade SS construction
- Supports optional diffuse sensor for enabling free entry/ exit operation



LED Direction  
Indicators

INGRESS  
PROTECTION  
RATING

**IP44**



100%  
Duty Cycle



Delay Time



Wired  
Terminal

## TECHNICAL SPECIFICATIONS

# V-PM4011BL-SGT3

Parameter	Specifications
Passage Width	Standard 600mm; optional 900mm
Throughput Rate	30-35 persons per minute
Drive	Brushless DC Motor 90K 40W
Passage Direction	Unidirectional/ bidirectional
Power/Mechanism Failure	Fail safe or fail lock status for either one or both directions be in free movement mode (standard) or locks in the home position
Fire Alarm Integration	Supported to provide free passage for evacuation
Service Life	>10 million operation cycles
Movement	Brushless Swing Gate movement
Communication Interface	Input (NO/NC/COMM) & RS485
Power Supply	DC 24V,150W
Power Consumption	50W
Relative Humidity	≤90% no condensation
Working Temperature	-20°C~+70°C
IP Rating	IP44
Door Material	SS304 with titanium plating, optional acrylic arm
Chassis Material	SUS304 (optional 316L grade)
Dimension	280x200x1020mm
Net weight	Approx. 25 kg
Certifications	CE, FCC, ROHS

\*Exact products and specifications shown may vary by geographic region and are subject to change without notice. Weights and measurements are approximate and may vary.

## DIMENSIONS:

Unit: mm

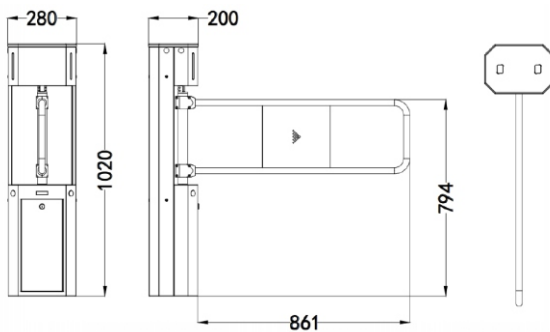

## SINGLE LANE DUAL P-GATE:



## P-TYPE ACRYLIC GATE:



## VANTAGE INTEGRATED SECURITY SOLUTIONS LIMITED.

B3, Bredon House 321, Tenttenhall Road Tettenhall, Wolverhampton

West Midlands, WV6 0JZ United Kingdom

Ph:+44-1902-793383, Email: sales@vantagesecurity.com

[www.vantagesecurity.com](http://www.vantagesecurity.com)

(AN ISO 9001 : 2008, ISO 14001:2004 CERTIFIED COMPANY)

