

PEOPLE ENTRANCE MANAGEMENT SYSTEM

V-PM3400DC-FBT3

DOUBLE MACHINE CORE FLAP BARRIER GATE



FEATURES

Heavy duty stainless steel Flap Barrier

LED Direction indicators at each side

Selectable operating modes- single direction, bi-direction, always free or always locked

IP44 Ingress Protection Rating

Automatic reset of barrier gate after each passage

Adjustable time out delay

Double anti-clipping function, photocell anti-clipping and mechanical anti-clipping

Integration support with any RFID/Biometric Reader through NO input

Top quality AISI 304 grade SS construction



LED Direction
Indicators

INGRESS
PROTECTION
RATING

IP44



100%
Duty Cycle



Delay Time



Wired
Terminal

TECHNICAL SPECIFICATIONS

V-PM3400DC-FBT3

Parameter	Specifications
Passage width	550mm
Throughput rate	35 p/m
Power supply	100~240 V AC
Motor voltage	24 V DC
Max power consumption	35W
Frequency	50~60 Hz
Protection level	IP 44
Working temperature	-25°C~+70°C
Electro-magnetic drive	DC
Dimension	1410x300x990mm
Net weight	100 kg
Certifications	CE, FCC, ROHS

*Exact products and specifications shown may vary by geographic region and are subject to change without notice. Weights and measurements are approximate and may vary.

DIMENSIONS

Unit: mm

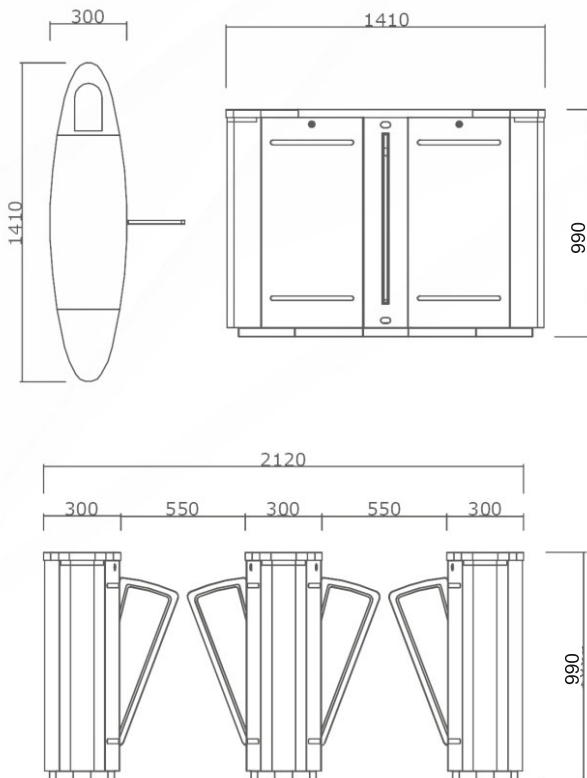

VANTAGE INTEGRATED SECURITY SOLUTIONS LIMITED.

B3, Bredon House 321, Tenttenhall Road Tettenhall, Wolverhampton

West Midlands, WV6 0JZ United Kingdom

Ph: +44-1902-793383, Email: sales@vantagesecurity.com

www.vantagesecurity.com

(AN ISO 9001 : 2008, ISO 14001 : 2004 CERTIFIED COMPANY)

