

# PEOPLE ENTRANCE MANAGEMENT SYSTEM

## V-PM1600DC-TST3 HALF HEIGHT DUAL LANE TRIPOD TURNSTILE GATE BARRIER

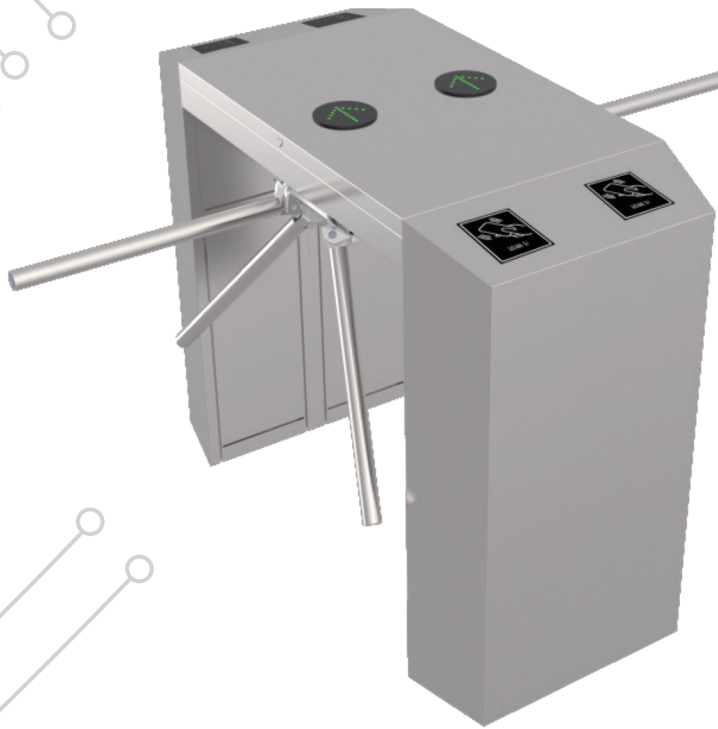

### FEATURES

Selectable operating modes- single direction, bi-direction, always free or always locked

Heavy-duty design for 24 hours continue application

LED Direction indicators at each side

IP44 Ingress Protection Rating

Automatic reset of barrier gate after each passage

Adjustable time out delay.

Integration support with any RFID/Biometric Reader through NO input



LED Direction Indicators



**IP44**



100%  
Duty Cycle



Delay Time



Wired Terminal

## TECHNICAL SPECIFICATIONS

# V-PM1600DC-TST3

Parameter	Specifications
Passage Width	550mm
Throughput Rate	Up to 35 p/m
Power Supply	100~240 V AC
Operational Voltage	24 V/DC
Max Power Consumption	35W
Frequency	50~60 Hz
Protection Level	IP44
Working Temperature	-25°C~+70°C
Electro-Magnetic Drive	DC
Dimension Excluding Bars	1200x560x980
Net Weight Including Bars	52 kg
Certifications	CE, FCC, ROHS

\*Exact products and specifications shown may vary by geographic region and are subject to change without notice. Product image, weights and measurements are approximate and may vary.

## DIMENSIONS

Unit: mm

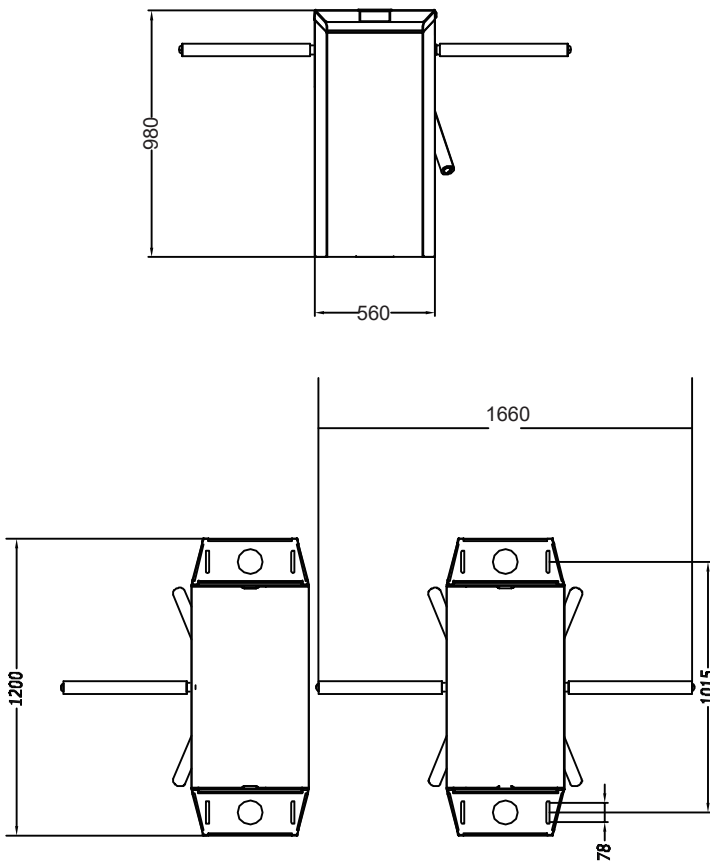

## VANTAGE INTEGRATED SECURITY SOLUTIONS LIMITED.

B3, Bredon House 321, Tenttenhall Road Tettenhall, Wolverhampton  
West Midlands, WV6 0JZ United Kingdom

Ph: +44-1902-793383, Email: sales@vantagesecurity.com

[www.vantagesecurity.com](http://www.vantagesecurity.com)

(AN ISO9001 : 2008, ISO14001:2004 CERTIFIED COMPANY)

